

### 男子団体 (BT)

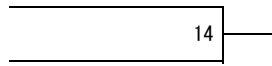

### 第2代表決定戦

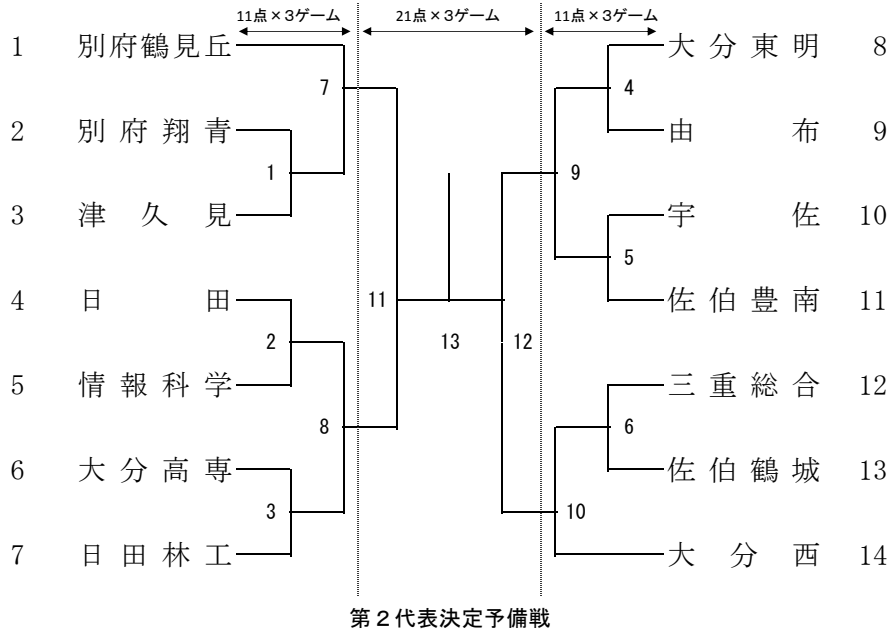
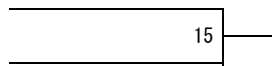

### 女子団体 (GT)

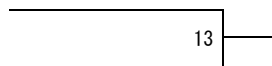
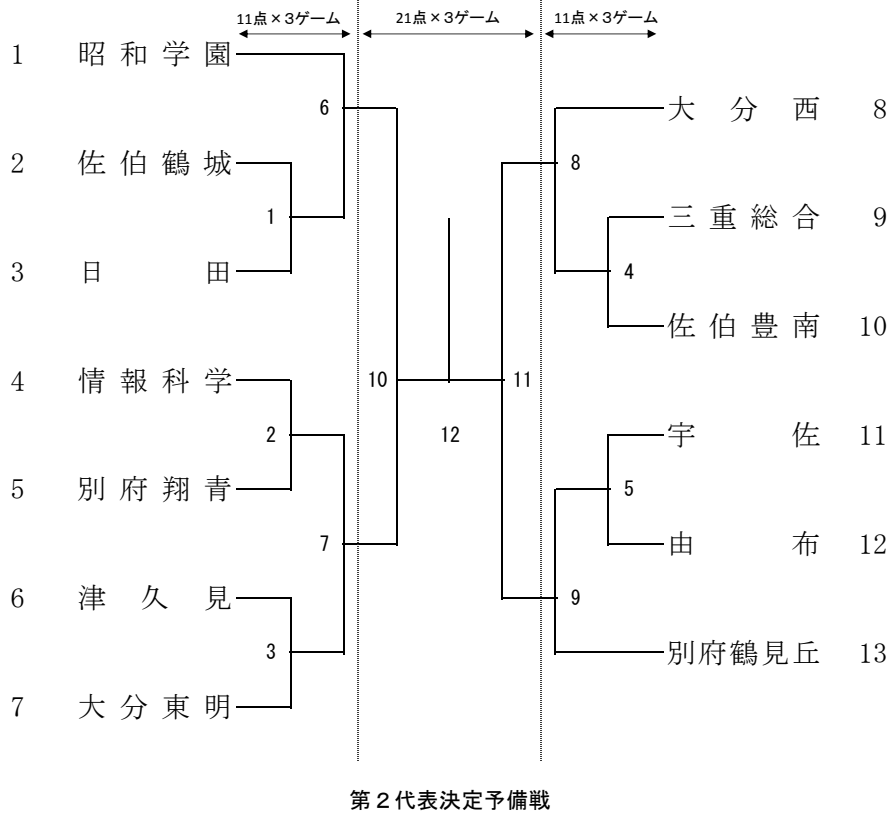

### 第2代表決定戦

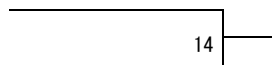

男子ダブルス (BD)

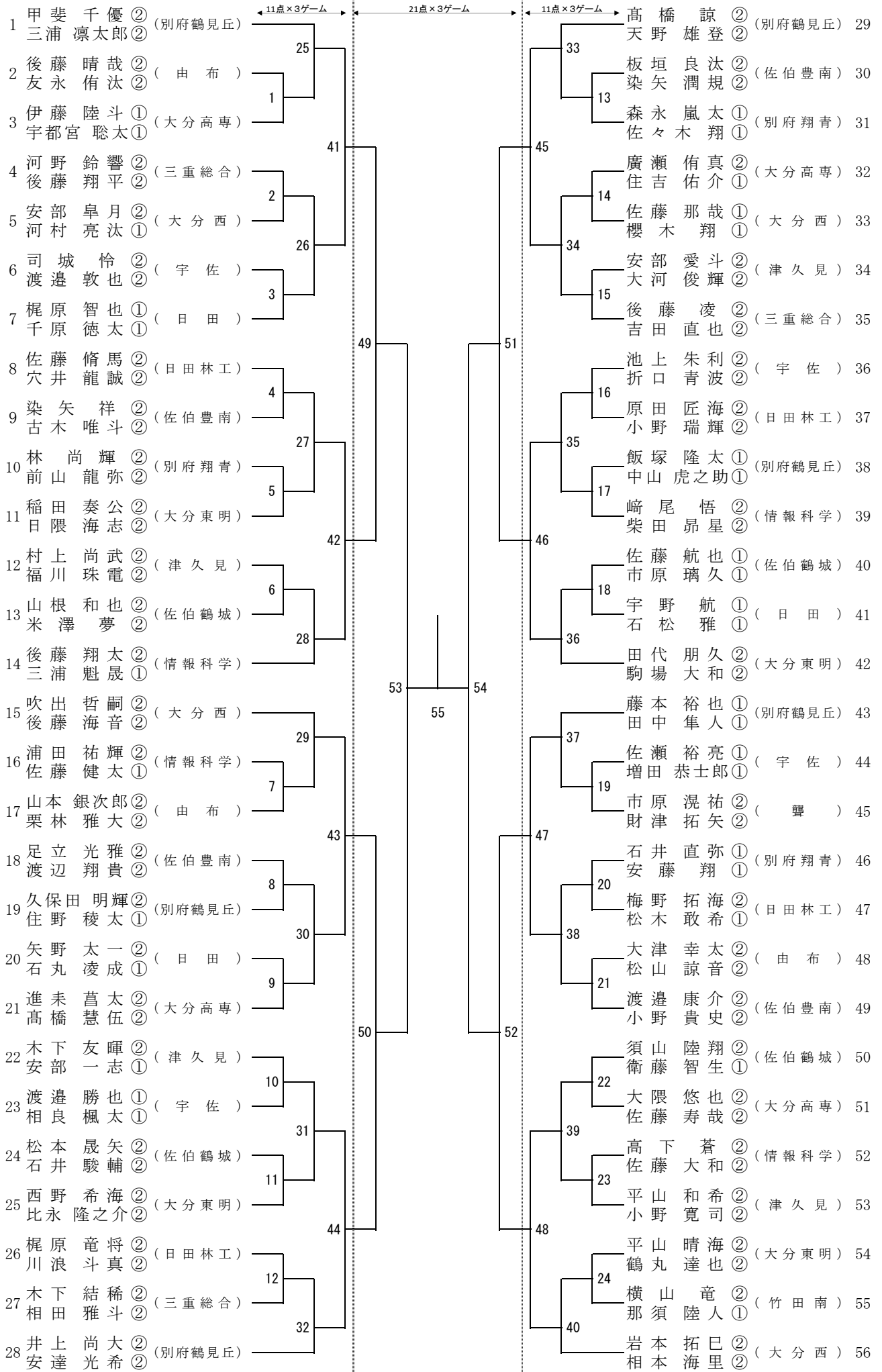

# 女子ダブルス (GD)

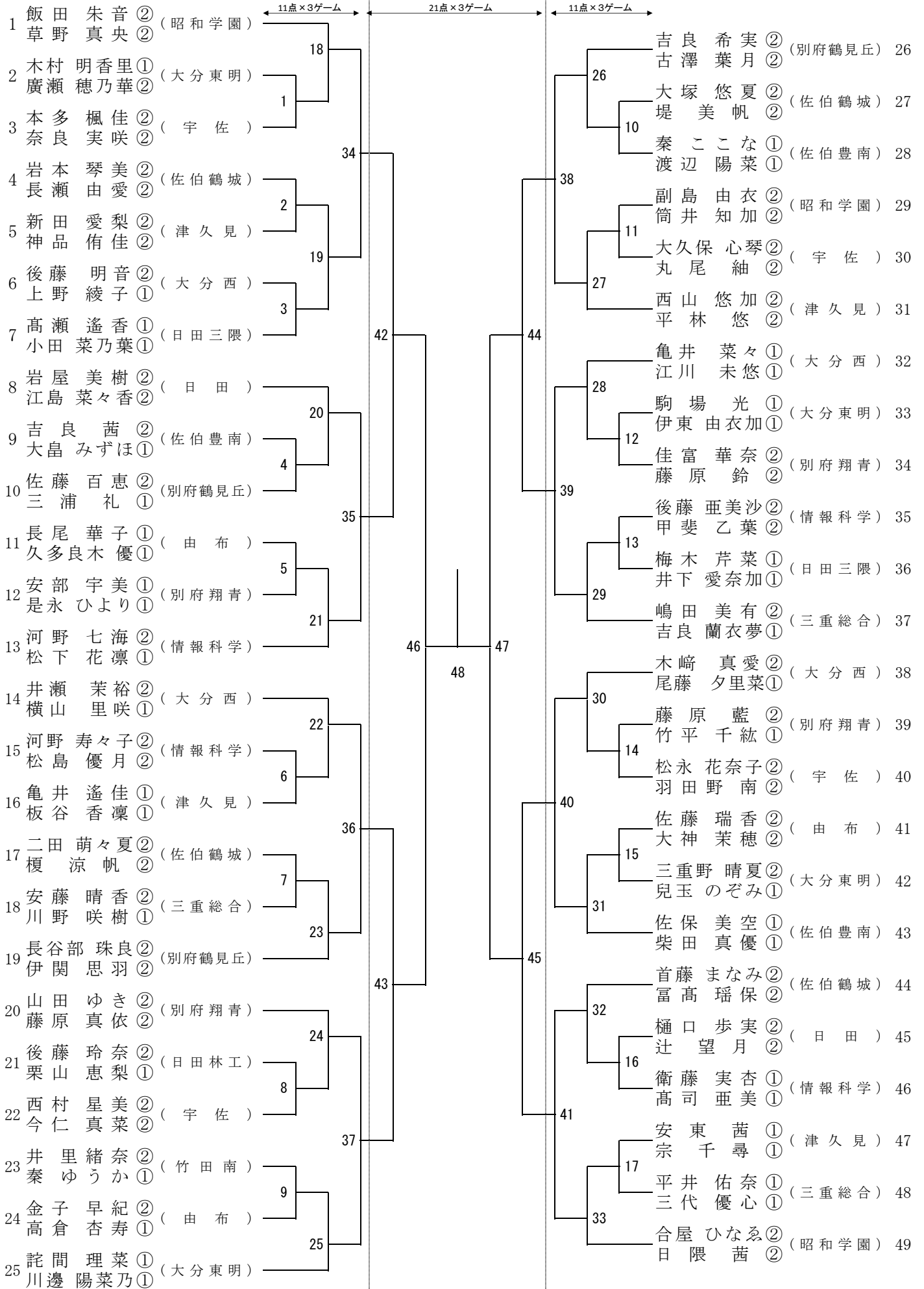

# 男子シングルス (BS)

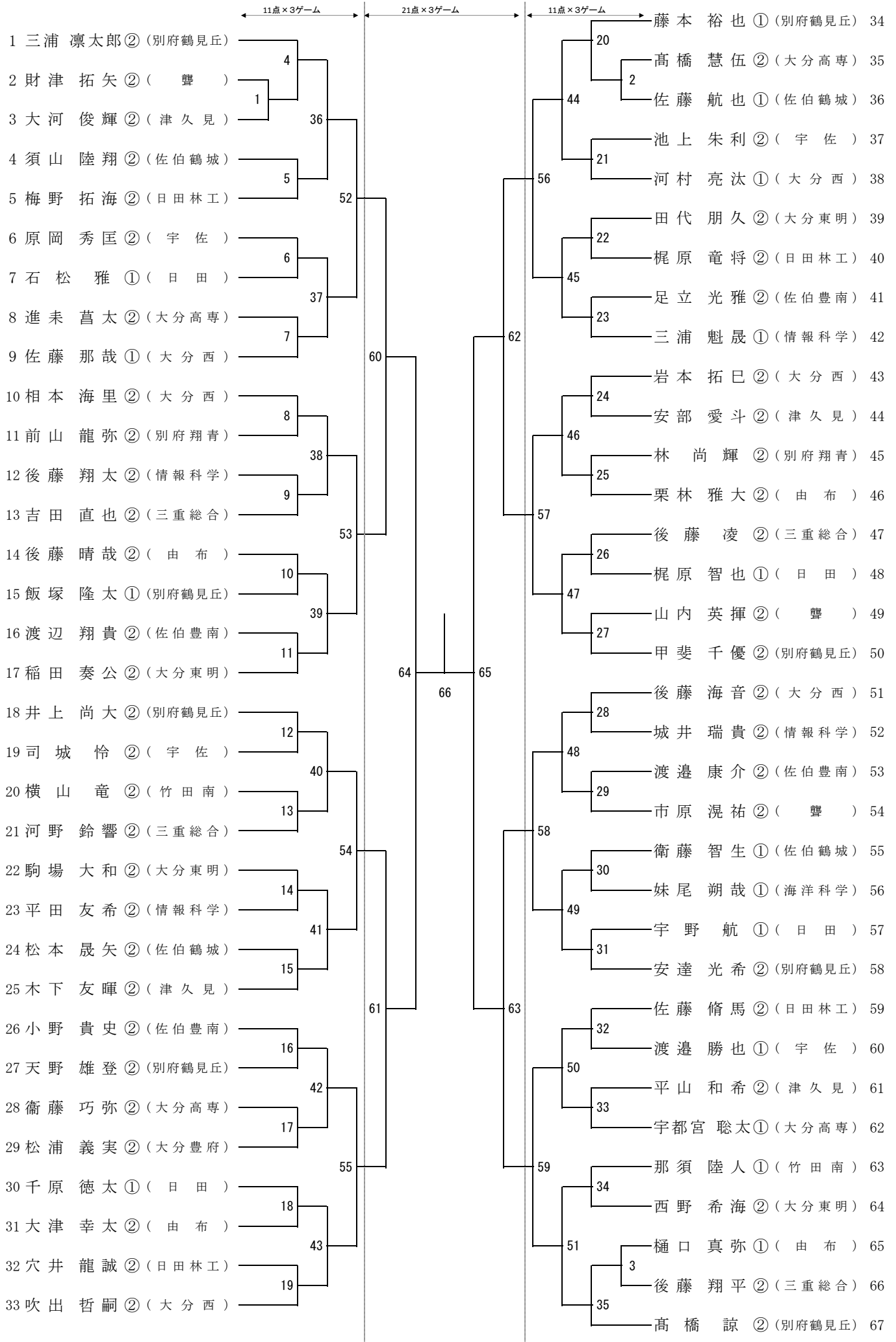

# 女子シングルス (GS)

